

# INSTRUCTION MANUAL

## G-5500



**YAESU MUSEN CO., LTD.**

1-20-2 Shimomaruko, Ota-Ku, Tokyo 146-8649, Japan

**YAESU U.S.A.**

17210 Edwards Rd., Cerritos, CA 90703, U.S.A.

**YAESU INTERNATIONAL DIVISION**, (Caribbean, Mexico, Central & So. America)

7270 NW 12th St., Suite 320, Miami, FL 33126, U.S.A.

**YAESU EUROPE B.V.**

Snipweg 3, 1118DN Schiphol, The Netherlands

**YAESU UK LTD.**

Unit 2, Maple Grove Business Centre,  
Lawrence Rd., Hounslow, Middlesex, TW4 6DR, U.K.

**YAESU GERMANY GmbH**

Am Kronberger Hang 2, D-65824 Schwalbach, Germany

**YAESU HK LTD.**

11th Floor Tsim Sha Tsui Centre, 66 Mody Rd.,  
Tsim Sha Tsui East, Kowloon, Hong Kong



# **YAESU G-5500**

## **ANTENNA AZIMUTH-ELEVATION ROTATORS & CONTROLLER**



The Yaesu G-5500 provide 450° azimuth and 180° elevation control of medium- and large-size unidirectional satellite antenna arrays under remote control from the station operating position. The two factory-lubricated rotator units are housed in weatherproof melamine resin coated die-cast aluminum, to provide maintenance-free operation under all climatic conditions. The rotators may be mounted together on a mast, or independently with the azimuth rotator inside a tower and the elevation rotator on the mast.

The controller unit is a handsomely-styled desktop unit with dual meters and direction controls for azimuth, in compass direction and degrees; and elevation, from 0° to 180°. An External Control jack is provided on the rear of the controller for interfacing via D-to-A converters to an external microcomputer or other display/controller.

Please read this manual carefully before installing the rotators.

## **SPECIFICATIONS**

<b>Voltage requirement:</b>	110-120 or 200-240 VAC
<b>Motor voltage:</b>	24 VAC
<b>Rotation time (approx., @60Hz):</b>	Elevation (180°): 67 sec. Azimuth (360°): 58 sec.
<b>Maximum continuous operation:</b>	5 minutes
<b>Rotation torque:</b>	Elevation: 14 kg-m (101 ft-lbs) Azimuth: 6 kg-m (44 ft-lbs)
<b>Braking torque:</b>	Elevation: 40 kg-m (289 ft-lbs) Azimuth: 40 kg-m (289 ft-lbs)
<b>Vertical load:</b>	200 kg (440 lbs)
<b>Pointing accuracy:</b>	±4 percent
<b>Wind surface area:</b>	1 m <sup>2</sup>
<b>Control cables:</b>	2 x 6 conductors - #20 AWG or larger
<b>Mast diameter:</b>	38-63 mm (1-1/2 to 2-1/2 inches)
<b>Boom diameter:</b>	32-43mm (1-1/4 to 1-5/8 inches)
<b>Weight:</b>	Rotators: 9 kg (20 lbs) Controller: 3 kg (6.6 lbs)

## **UNPACKING & INSPECTION**

When unpacking the rotator confirm the presence of the following items:

Elevation Rotator Unit.....	1
Azimuth Rotator Unit.....	1
Controller Unit.....	1
Mast Clamp (pair).....	2
Pipe clamp.....	2
U Bracket.....	1
M8 x 16 Hex. Bolt.....	4
M8 x 25 Hex. Bolt.....	8
M8 x 70 Hex. Bolt.....	4
M8 x 95 Hex. Socket Bolt.....	1
U-Bolt.....	2
6mm Spring Washer.....	4
6mm Flat Washer.....	4
8mm Spring Washer.....	18
8mm Flat Washer.....	12
M8 Square Nut.....	1
M8 Hex. Nut.....	4
M6 Hex. Nut.....	4
8-pin DIN Plug.....	1
7-pin Metal Connector.....	2
Water Resist Cap.....	2
Spare Fuse (117V:2A, 220V:1A).....	1
Instruction Manual.....	1

If any of these items are missing or appear to be damaged, save the carton and packing material and notify the shipping company (or dealer, if purchased directly at his shop).

Before proceeding with installation, confirm that the AC voltage label on the rear of the Controller matches your local line voltage: either “117V” for 110 to 120 VAC, or “220” for 220 to 240 VAC. If the labeled voltage range does not match, return the controller to the dealer from whom you purchased it (different power transformers are installed for the different voltage ranges).

Note that cable is not included with the rotator, as the length must be determined case-by-case. Contact your Yaesu dealer to obtain the length of cable your installation requires. For runs of over 100 feet, use #18 AWG instead of #20 AWG.

## CONTROL CABLE PREPARATION & CONNECTION

Before installing the antenna and rotators, make all connections and test rotator operation thoroughly on the ground as described below.

Your control cables should have six conductors each of at least #20 AWG gauge (if less than 100 feet long).

1. Assemble the cable according to the following diagrams.
2. Connect each wire to the terminals on the rear panel of the controller, making sure to match the numbers on the pins, and insert the connector to the Jack on the rotator.
3. On the controller, make sure that the **POWER** switch is in the 'OFF' position, and connect the line cord to the AC power outlet.
4. Turn on the **POWER** switch. The meter lamps should light and the **ELEVATION** meter indicate to the center of the scale (90°).
5. Press the **UP** switch. The elevation rotator should turn as the meter indication moves to the right. Release the **UP** switch and confirm that the rotator slowly stops.
6. Repeat step 5, pressing the **DOWN** switch instead of the **UP** switch. The elevation rotator should turn in the opposite direction as the meter indication moves to the left.
7. If operation does not occur as described above, check for a wiring error in the elevation cable connections.
8. Press the **LEFT** switch. The azimuth rotator should turn counterclockwise as the meter indication moves to the left. Release the **LEFT** switch and confirm that the rotator slowly stops.
9. Repeat step 8, pressing the **RIGHT** switch instead of the **LEFT** switch. The azimuth rotator should turn clockwise as the meter indication moves to the right.
10. If operation does not occur as described in steps 8 and 9, check for a wiring error in the azimuth cable connections.
11. When everything checks out in the above steps, slide the water resist cap over the connectors on the rotator. Remove the cable clamps from the controller, clip them over the cables, and screw them back onto the controller. Then replace the two controller terminal covers.

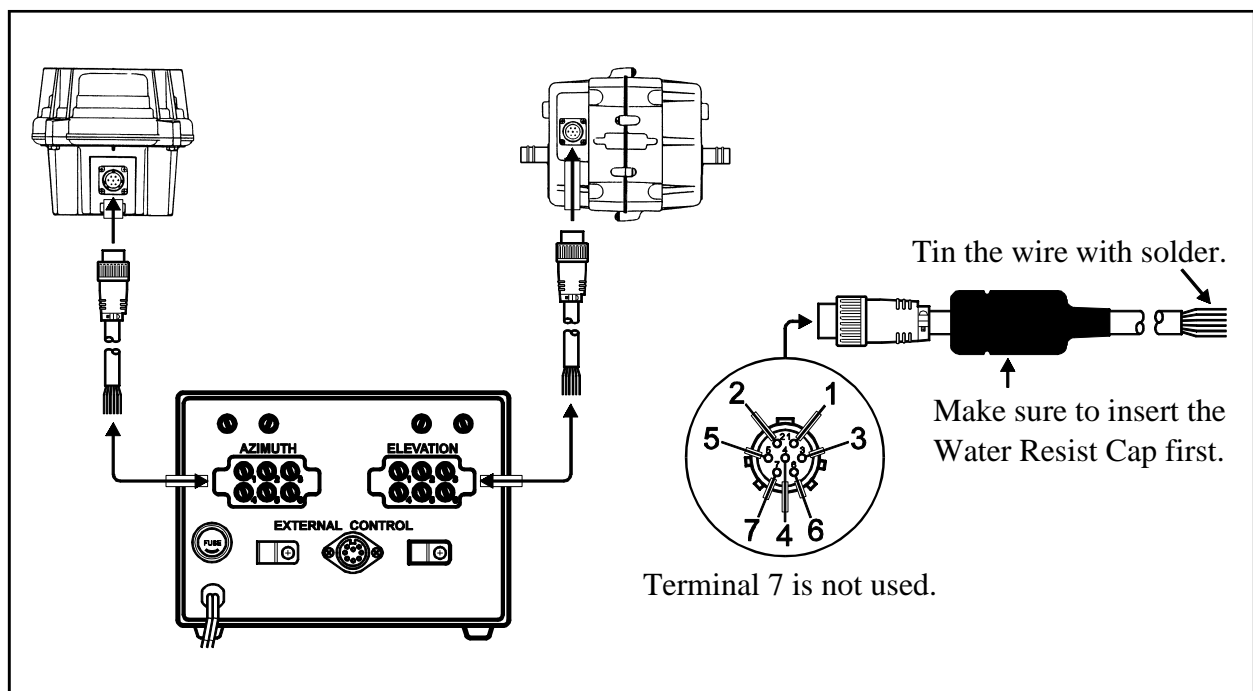

## PRE-INSTALLATION ADJUSTMENT

Switch the controller off and adjust the **0. ADJ** screws beneath each meter face, if necessary, so that each meter points to the left edge of the scale. Then turn the controller back on for the following steps.

### Azimuth Indicator

Press and hold the **LEFT** switch and allow the azimuth rotator to turn until it reaches its end stop. Note the precise position of the rotator (mark the housing, if necessary), and then press and hold the **RIGHT** switch to bring the rotator around one full turn to exactly the same position. The meter should now point precisely to 360° of the scale. If not, adjust the **FULL SCALE ADJ** potentiometer at the upper corner of the rear panel above the **AZIMUTH** terminals.

Press the **RIGHT** switch again to continue clockwise rotation until the rotator reaches its end-stop. The indicator should now point to right edge (90°) of the scale.

### Elevation Indicator

Press the **UP** switch to align the 180° markers on the rotator. The meter should now point precisely to 180° at the right end of the scale. If not, adjust the **FULL SCALE ADJ** potentiometer at the upper corner of the rear panel above the **ELEVATION** terminals.

### Notes on Controller Operation:

- The rotator motors are rated for five-minutes intermittent duty. However, they be brought to rest for at least 15 minutes afterwards.
- If both **UP** and **DOWN** switches or **RIGHT** and **LEFT** switches are pressed at the same time, the corresponding rotator turns up or right (clockwise).
- Release the switch when the meter indicates in the end zones (the rotator stops).
- Remember to turn the controller off when the rotators are not in use.

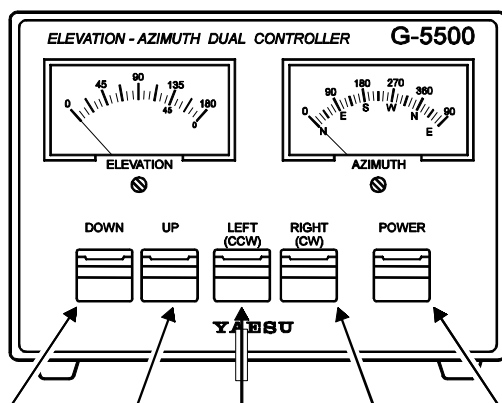

**DOWN Switch    UP Switch    LEFT Switch    RIGHT Switch    POWER Switch**

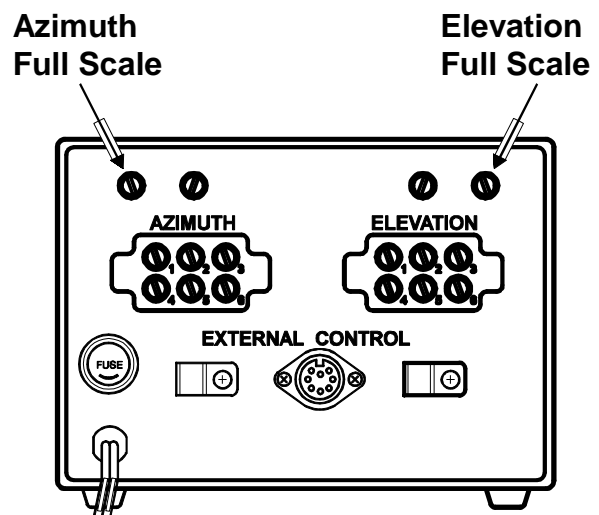

## EXTERNAL CONTROL

IF the optional GS-232 Computer Control Interfaces Unit is installed, the RS-232C cable from the computer routes through this grommet, and is affixed in place by the nylon cable clamp.

Pin	Function
6	Provides 2 to 4.5VDC corresponding to 0 to 450°
1	Provides 2 to 4.5VDC corresponding to 0 to 180°
4	Connect to Pin 8 to rotate left (counterclockwise)
2	Connect to Pin 8 to rotate right (clockwise)
5	Connect to Pin 8 to rotate DOWN
3	Connect to Pin 8 to rotate UP
7	Provides DC13V to 6V at up to 200mA
8	Common ground

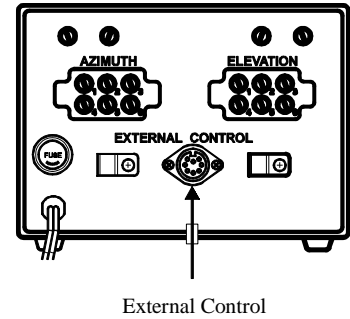
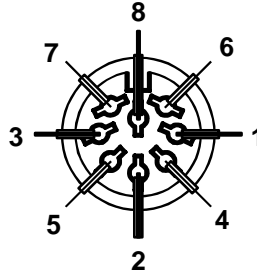

## ROTATOR INSTALLATION

The maximum safe load of the G-5500 depends on the physical size of the antenna, method and quality of mechanical installation, and maximum wind velocity at the installation site.

Notice that the preferred mounting method requires that each antenna be attached to the boom at its center of gravity, with the boom then attached to the elevation rotator at its center of gravity. This minimizes stress on the rotator and supporting structure, especially during strong winds.

The azimuth rotator may be mounted at the top of the mast together with the elevation rotator, or separately inside of a supporting tower. The latter method is generally stronger, and preferable in high wind locations or for large antennas, but requires some additional hardware not supplied with the G-5500 kits.

### Mounting the Rotators Together

**NOTE:** If the elevation rotator is to be mounted on the mast alone, skip this section and see “Mounting the Rotators Separately”.

1. Bolt the U-bracket to the top of the azimuth rotator using four M8x16 bolts, spring washers and flat washers.

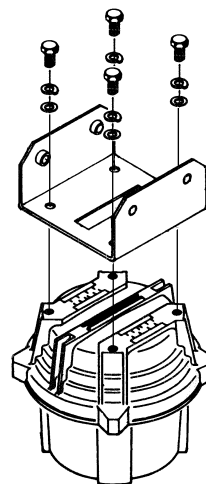

2. Insert the elevation rotator into the U-bracket, then fasten the elevation rotator using four M8x25 bolts, spring washers and flat washers.

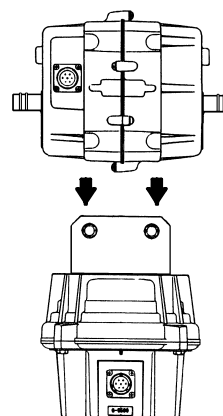



# G-5500 Antenna Azimuth-Elevation Rotators & Contro

## Mounting the Rotators Separately

Only do this if the elevation rotator is to be mounted alone on the mast. You will need four long stud bolts and four additional pipe clamps (available from your dealer).

1. Slip an 8 mm spring washer over the short-thread end of each stud bolt (x4), and screw the stud bolts firmly into holes in the side of the elevation rotator.

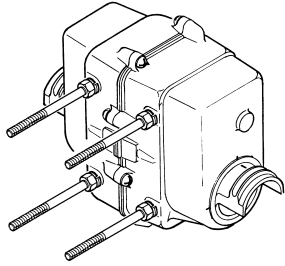

2. Slip an 8 mm flat washer over each installed stud bolt, and then the pipe clamps. Place another flat washer and then a spring washer over the end of each stud bolt, and start a nut on each to hold the hardware in place.

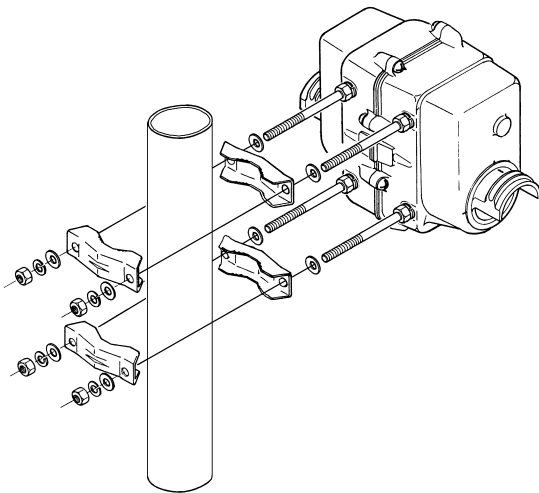

## Installing the boom in the Elevation Rotator.

Do these steps for all installations.

1. Slide the boom through the rotator.
2. Place one U-bolt over each arm of the rotator, and assemble one pipe clamp, flat washers, spring washers and nuts on the U-bolts. Center the boom carefully, and alternately tighten the nuts on each U-bolt 1/2-turn beyond the point where the spring washers are flattened.

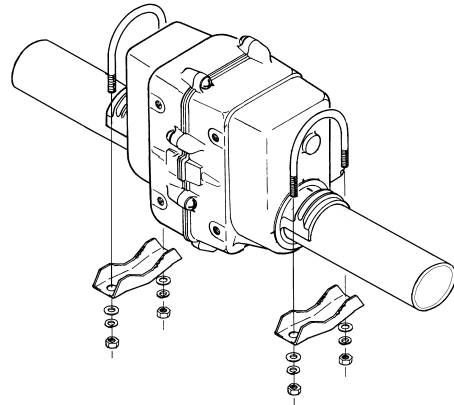

Be sure to leave enough slack in both the elevation control cable and the coaxial cable feedline around the azimuth rotator so the antenna can rotate 450° without straining the cable or feedline.

For dual parallel arrays, feedlines should be taped to the boom on either side of the rotator, with enough slack left to allow 180° rotation without stressing the feedlines.

No	Qty	DESCRIPTION
1	8	8° Spring Washer
2	8	8° Nut
3	8	8° Washer
4	4	8° Stud Bolt
5	6	Boom/Mast Clamp
6	2	U Bolt
7	4	6° Washer
8	4	6° Spring Washer
9	4	6° Nut

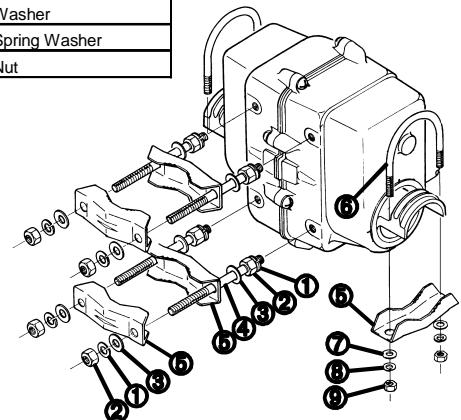

## Mast Bracket Attachment in the Azimuth Rotator & Antenna Positioning

**Important!!** Before mounting the mast to the azimuth rotator, a single hole must be drilled through the bottom of the mast to accommodate an anti-twist support bolt used in the base support bracket halves:

1. Drill a 9 mm diameter hole through both walls of the mast, centered 50 mm from the mast bottom (see Figure 1). Ensure the drill is maintained perpendicular and centered when making the hole, to ensure proper alignment of the holes in the mast and those in the base support clamp.
2. Referring to Figure 2, loosely fasten the mast bracket halves **A** to the rotator housing using four M8x25 bolts **A**, flat washers and spring washers.
3. Insert the mast into the bracket, and finger-tighten the four M8x70 bolts **A** with spring washers and nuts **A**. Note that one side of the bracket has ridges on either side of the bolt holes: the bolts should be inserted from this side, so the ridges hold the bolt head from turning.
4. Finger-tighten the M8x95 socket bolt **Ä** with nut **Ä**.
5. With the rotator connected, set the controller so that it indicates precisely 0° (North). Then, using an accurate map and known landmarks, position the antenna (without using the controller) so that it points to true North. Alternatively, consult a Geodetic Survey map for your area to determine the

6. When you are satisfied with the orientation of the antenna, center the mast on the top of the azimuth rotator, and begin tightening the M8x25 bolts **A** on each side alternately so that the gap on each side of the mast remains the same. Markings are provided on the top of the azimuth rotator to assist this process.
7. Confirm that the mast and bracket are precisely centered on the azimuth rotator, and tighten the four bolts **A** affixing the mast bracket to the top of the azimuth rotator.

### Warning !!

- m Take care not overtighten the four bracket bolts. Do not torque the bolts beyond the point where the spring washer flattens.
- m The azimuth rotator is designed for vertical mounting only. One half of the housing is marked “**TOP SIDE**”. Water and contaminants will damage the motor unit if it is mounted horizontally or upside-down.

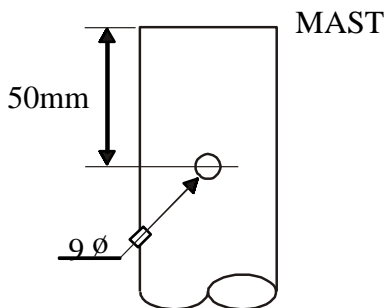

Figure 1

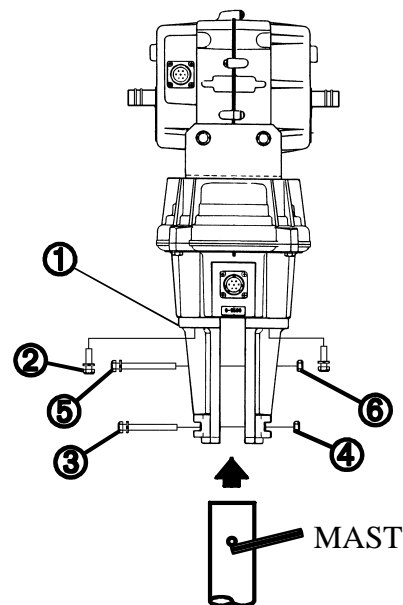
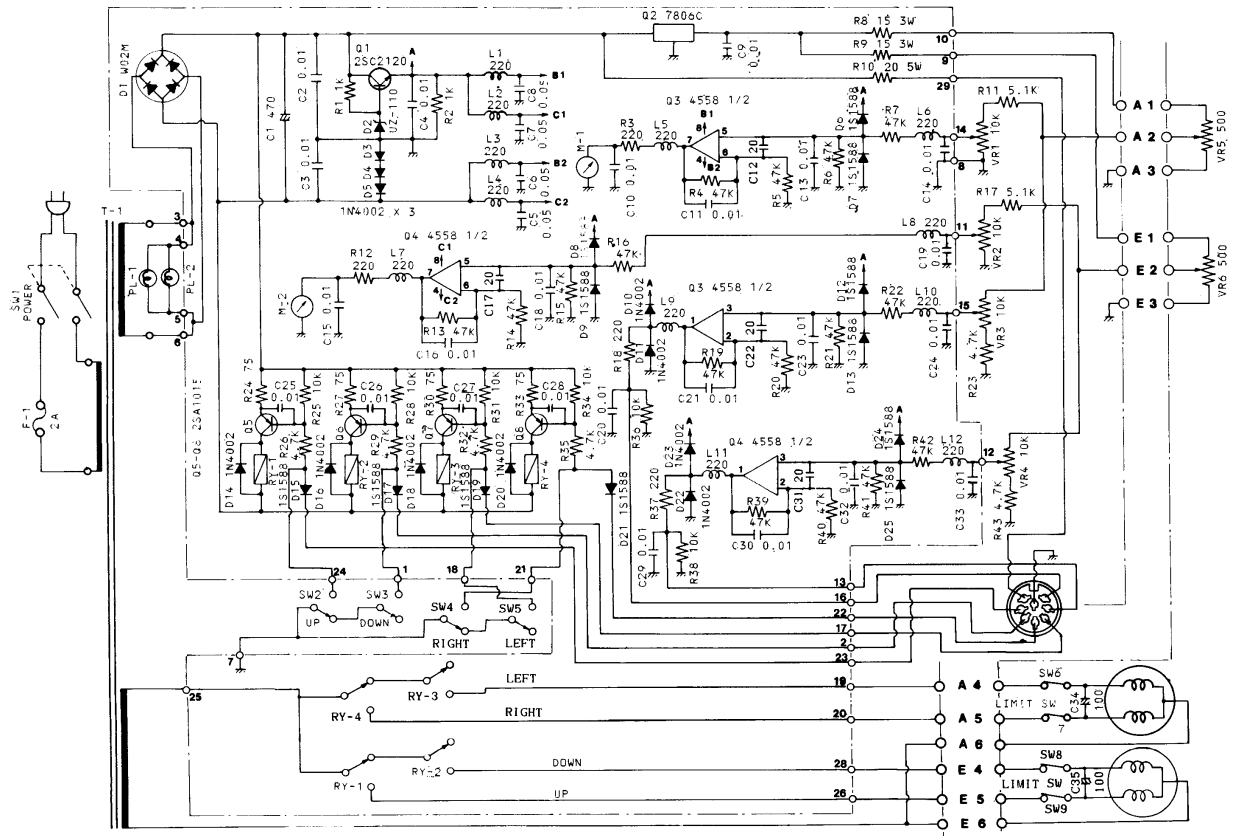

Figure 2

# G-5500 Schematic Diagram



# **YAESU**

*...leading the way.<sup>SM</sup>*

**Copyright 1998  
Yaesu Musen Co., Ltd.  
All rights reserved.**

**No portion of this manual  
may be reproduced without  
the permission of  
Yaesu Musen Co., Ltd.**

**Printed in Japan.**